



Flipping Physics Lecture Notes:

Free Response Question #2 - AP Physics 1 - 2015 Exam Solutions

<http://www.flippingphysics.com/ap1-2015-frq2.html>

AP® is a registered trademark of the College Board, which was not involved in the production of, and does not endorse, this product. This Experimental Design question also works as a part of the AP Physics C: Electricity and Magnetism curriculum.

- (1) In one second, do fewer electrons leave the bulb than enter the bulb?
 (2) Does the electric potential energy of electrons change while inside the bulb?

Note: You should already know the answers to these questions, however, the question isn't asking for the answer to these questions, but rather for you to show you know how to set up an experiment to determine the answers.

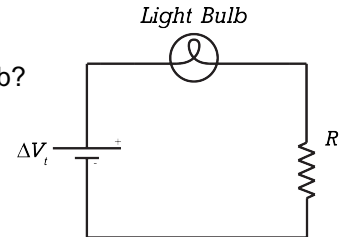

We need to start by drawing a circuit diagram of a lightbulb in series in a circuit with a power source. Then we need to add an ammeter in series with and before the lightbulb to measure the current going into the lightbulb, an ammeter in series with and after the lightbulb to measure the current leaving the lightbulb and a voltmeter in parallel with the lightbulb to measure the electric potential difference across the lightbulb.

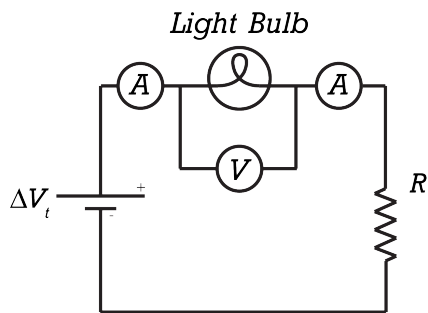

Part (a): Place ammeters in series with the lightbulb both before and after the lightbulb. Use the ammeters to measure the current both before and after the lightbulb. Place a voltmeter in parallel with the lightbulb. Use the voltmeter to measure the electric potential difference across the lightbulb.

Part (b i): If the current in both ammeters is the same, then the number of electrons which flow into the lightbulb will be the same as the number of electrons which flow out of the lightbulb. If the two currents are not the same, then the number of electrons would not be the same.

Part (b ii): Electric potential difference equals the change in electric potential energy per unit charge. Therefore, if the electric potential difference across the lightbulb is nonzero, then the electric potential energy of the electrons will change while inside the bulb.

Part (c i): We actually don't need to adjust the setup, however, one of the ammeters is superfluous because we know the current is the same before and after the lightbulb.

Part (c ii): We need to adjust the electric potential difference across the power supply and take multiple measurements of the current through the battery and the electric potential difference across the battery.

Part (d): Because Ohm's Law is $\Delta V = IR \Rightarrow R = \frac{\Delta V}{I}$ & $slope = \frac{rise}{run} = \frac{\Delta y}{\Delta x}$, we can create a graph

with the electric potential difference measurements across the lightbulb on the y-axis and the current measurements through the lightbulb on the x-axis. If the resistance of the lightbulb is ohmic, then we should be able to draw a best fit line which approximates all the data well. If the resistance of the lightbulb is nonohmic, then we should not be able to draw a best fit line which approximates all the data. The best fit line does not have to go perfectly through all of the measured data, it only needs to approximate the data. This is because of the uncertainties in the measured data.

Note: The answer to this problem is completely different than free response question #1. The answers to this free response question are essentially all short answer and you have to design an experiment. You can pretty much guarantee every AP Physics 1 exam will have a short answer free response question where you have to design an experiment. And again, this problem is completely devoid of numbers. So again, I ask you to Let Go of Your Numbers Dependency!!